

SELF-PRIMING PUMP

FEATURES

Tube:	Stainless Steel and Tefzel
Body:	Bronze
Impeller:	Jabsco Neoprene Compound
Shaft:	Type 316 Stainless Steel
Ports:	2" IPT
Seal:	Carbon-Ceramic Face Type
Bearings:	Sealed Ball Bearings
Shipping Weight:	19 lb (8,6 kg)

APPLICATIONS

MARINE: Engine cooling, Pumping bilges, Washdowns, Circulating water in bait tanks, Utility dock side pump.

INDUSTRIAL: Circulating and transferring, Velocity-mixing, Return spill, Sump drainage, Chemicals, Pharmaceuticals, Soap, Liquors, Inks, Dyes, Alcohol, Tanning Liquors, Glycerine, Brine, etc.

FARMING: Pumping water for stock, Pumping water from shallow wells and cisterns.

INSTALLATION

Pump may be mounted in any position. Intake and discharge ports are determined by the direction of shaft rotation (refer to dimensional drawing). Before installing, turn pump shaft in the direction of shaft rotation.

NOTICE: If pulley or coupling must be pressed on shaft, remove end cover and impeller to support shaft from impeller end during press operation. Do not hammer pulley or coupling on shaft; this may damage bearings or seal.

NOTE: Model 18370-0000 is interchangeable with earlier pump model 10490-0001: Base mounting dimensions, height above base to shaft and height above base to port centerline, are the same.

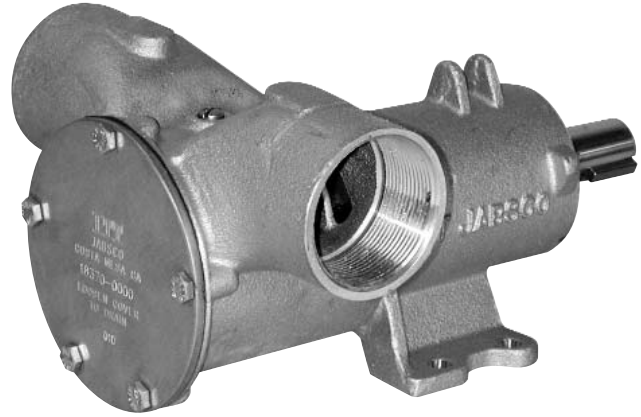

Model 18370-0000

OPERATION

Pump will self-prime at low or high speeds. Make sure that all connections are airtight. **DO NOT RUN PUMP DRY FOR MORE THAN 30 SECONDS. LACK OF WATER FLOW MAY DAMAGE IMPELLER.** To drain pump, loosen end cover screws. See Head Capacity Table for head pressures and flow. To avoid costly shutdowns, keep a Jabsco Service Kit on hand.



WARNING Injury hazard. Exposed pulleys and belts can cause injury. Install shield around pulleys and belts. Stay clear while machinery is operating.

EXPLODED VIEW

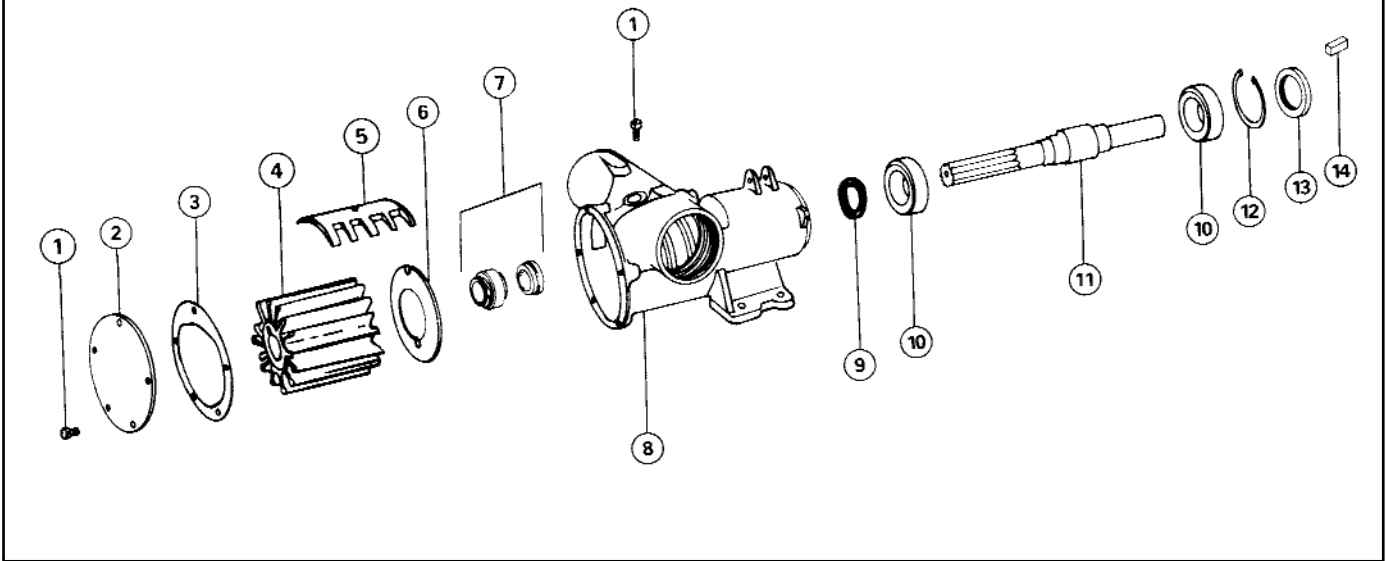

PARTS LIST

Key	Description	Quantity Required	Part No.
1	Screw (End Cover)	6	91005-0040
2	End Cover	1	12062-0000
3	*Gasket	1	816-0000
4	*Impeller	1	17936-0001
5	Cam	1	6988-0000
6	Wearplate	1	2574-0000
7	Seal Assembly (shaft)	1	6408-0000
8	Body	1	18313-0001
9	Inner Bearing Seal	1	92701-0180
10	Ball Bearing	2	92600-0260
11	Shaft	1	10487-0020
12	Retaining Ring	1	18725-0000
13	Outer Bearing Seal	1	818-0000
14	Drive Key	1	9214-0000
	Service Kit		90254-0001

- NOTE:**
1. ALL REPLACEMENT PARTS SHOWN ARE INTERCHANGEABLE WITH EARLIER PUMP MODEL 10490-0001.
 2. MODEL 18370-0000 HAS A ONE-PIECE BODY AND BEARING HOUSING DESIGN, WHICH REPLACED THE TWO-PIECE DESIGN OF MODEL 10490-0001.

* Parts contained in Service Kit.

SERVICE INSTRUCTIONS

Impeller Replacement: Remove end cover and gasket. Pull impeller out by grasping hub or blades with pliers. Replace impeller, gasket and end cover. A light coating of grease in impeller bore will aid priming on dry startup. (Use correct Jabsco gasket; a thicker or thinner gasket may cause impeller damage.) Standard gasket is 0.015" thickness.

Shaft Seal Replacement: Remove end cover, gasket, and impeller as outlined above. Loosen cam screw and remove cam (Key 5) (clean off sealant). Remove wearplate (Key 6) with screwdriver or hooked wire.

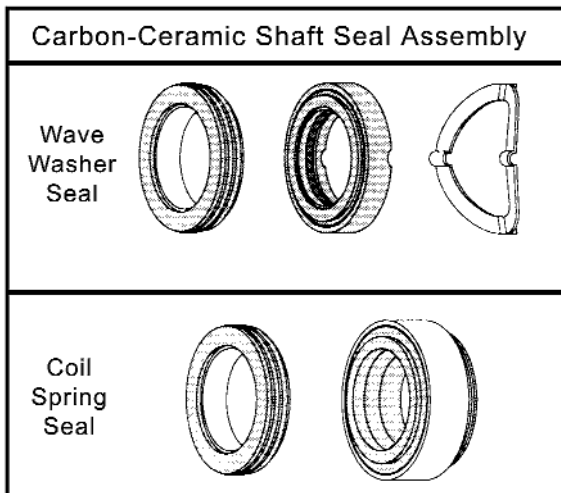

Older models of this pump were fitted with a shaft seal that was compressed by a wave washer type compression spring. When replacing this older seal assembly with a new style seal that is compressed by an integral coil type spring, remove and discard the wave washer.

Using a hooked wire, and taking care not to scratch shaft of seal seat bore, remove all components of seal assembly. Inspect shaft and seal seat bore to be sure sealing surfaces are free of nicks or scratches. Clean shaft surface behind splines to insure proper O-ring seal on shaft. Apply a light film of grease on shaft surface behind spline area. Thoroughly clean seal faces (carbon and ceramic) of all grease, oil or particles — this will insure that seal faces will turn freely on startup. Place ceramic seat assembly in body with boot first. Use care not to damage ceramic surface. Be sure ceramic and boot are bottomed squarely on body bore. Slide carbon ring assembly, with carbon facing ceramic, over the shaft and firmly up against the ceramic seat. If carbon portion of seal does not have an integral coil type tensioning spring, slide wave washer over the shaft and against the rubber boot on metal case containing O-ring and carbon. Replace wearplate, aligning notch with dowel pin in body. Apply a thin coat of sealant to top of cam and threads on cam screw and install in impeller bore (leave cam screw loose). Replace impeller, gasket and end cover. Tighten end cover screws. Tighten cam screw.

Major Repair: Remove pump from installation for major repair.

DISASSEMBLY

Remove end cover, impeller, cam, wearplate and seal assembly as outlined in Shaft Seal Replacement instructions. Remove outer bearing seal (Key 13) by prying with screwdriver. Remove retaining ring (Key 12) with retaining ring pliers. While pressing on impeller end of shaft, slide shaft, and bearing seal (Key 9). If ball bearings (Key 10) on shaft are worn, remove by pressing on inner race of bearing (inner bearing must be pressed off over impeller end of shaft, and the outer bearing over drive end of shaft). Replace all worn or broken parts.

ASSEMBLY

While supporting inner race of bearings, press new ball bearings onto a clean well-oiled shaft. Wipe excess oil from impeller end of shaft. Press new bearing seal (Key 9) into seal bore. Support the outer race of bearing while pressing shaft and bearing assembly (splined end fires) into body bearing bore. Install retaining ring (Key 12). Press new wearplate, cam, gasket and end cover as outlined in Shaft Seal Replacement instructions.

DIMENSIONAL DRAWING
Inches (Millimetres)

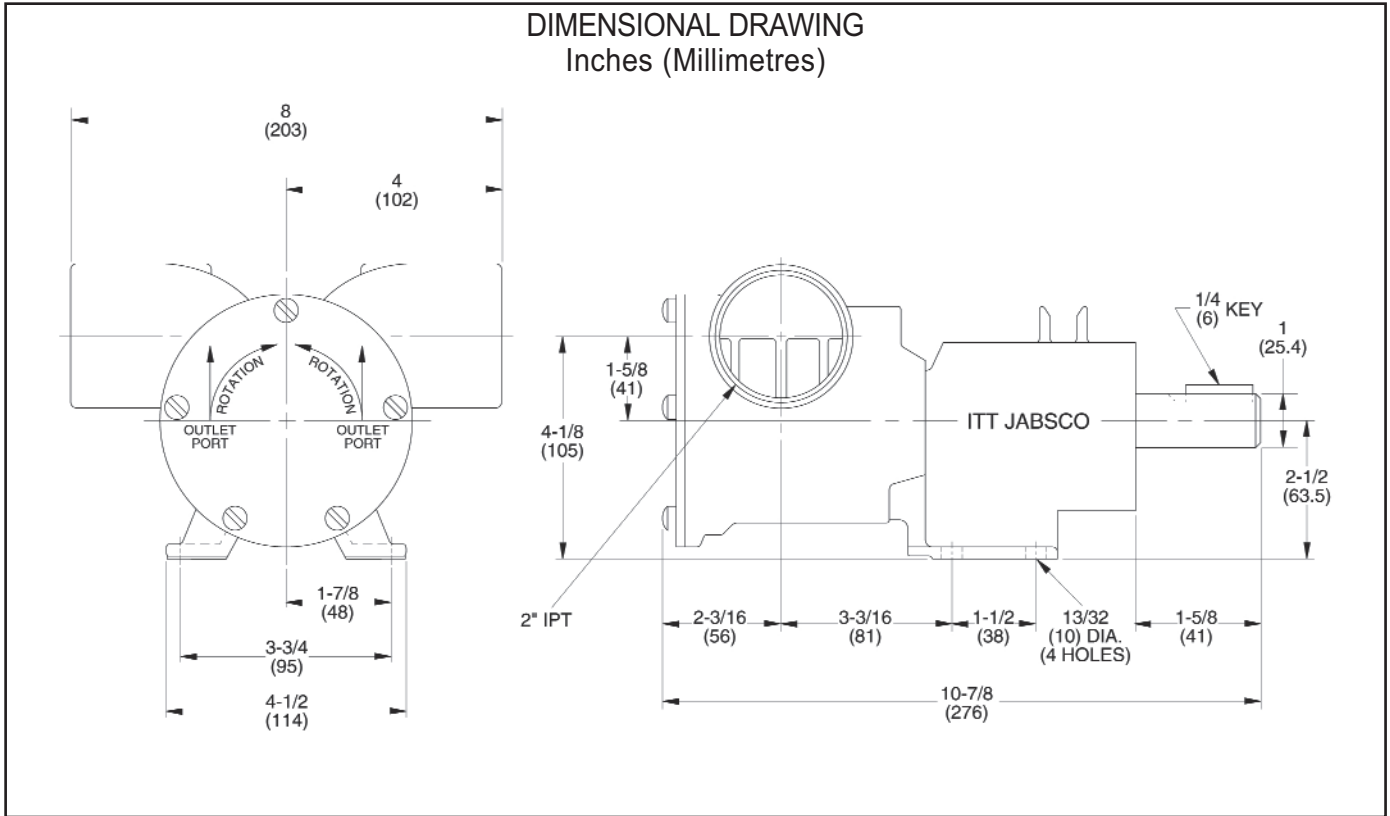

HEAD CAPACITY TABLE

Total Head				500 RPM			870 RPM			1160 RPM			1450 RPM			1750 RPM		
psi	kg per sq cm	feet of water	meters of water	GPM	L/Min	HP	GPM	L/Min	HP	GPM	L/Min	HP	GPM	L/Min	HP	GPM	L/Min	HP
4.3	0,3	10	3,0	23	87	1/2	40	151	1	54	204	1	70	265	1-1/2	83	314	2
8.7	0,6	20	6,1	22	83	1/2	37	140	1	50	189	1	66	250	1-1/2	79	299	2
17.3	1,2	40	12,2	17	64	1/2	30	144	1	43	163	1-1/2	58	220	1-1/2	71	269	3
26.0	1,8	60	18,3	—	—	—	22	83	1-1/2	34	129	1-1/2	48	182	2	61	231	3
30.3	2,1	70	21,3	—	—	—	—	—	—	—	—	—	41	155	2	55	208	3

HEAD CAPACITY TABLE

Total Head				2100 RPM			2450 RPM		
psi	kg per sq cm	feet of water	meters of water	GPM	L/Min	HP	GPM	L/Min	HP
4.3	0,3	10	3,0	95	360	3	108	409	3
8.7	0,6	20	6,1	91	344	3	104	394	3
17.3	1,2	40	12,2	82	310	3	93	352	5
26.0	1,8	60	18,3	70	265	5	81	307	5
30.3	2,1	70	21,3	62	235	5	73	276	5

NOTE: Progressively longer life may be expected as operating pressures and speeds are reduced. Factory Application Engineering assistance suggested for operation in light shaded area and recommended for heavy shaded area. Table shows approximate Head-Flow for new pump in U.S. gallons per minute.

xylem
Let's Solve Water

www.xyleminc.com

UK
Xylem
Bingley Road, Hoddesdon
Hertfordshire EN11 0BU
Tel: +44 (0) 1992 450145
Fax: +44 (0) 1992 467132

USA
Xylem
100 Cummings Center Drive
Suite 535-N, Beverly, MA 01915
Tel: +1 978 281-0440
Fax: +1 978 283-2619

ITALY
Xylem
Via Tommaseo, 6
20059 Vimercate, Milano
Tel: +39 039 685 2323
Fax: +39 039 666 307

GERMANY
Xylem
Oststrasse 28
22844 Norderstedt
Tel: +49-40-53 53 73-0
Fax: +49-40-53 53 73-11

JAPAN
Xylem
3-21-10, Shin-Yokohama
Kohoku-Ku, Yokohama, 222-0033
Tel: +81-045-475-8906
Fax: +81-045-477-1162

Warranty: All products of the company are sold, and all services of the company are offered subject to the company's warranty and terms of sale, copies of which will be furnished upon request. Details correct at time of printing. We reserve the right to change specifications without prior notice.